



Portoni sezionali industriali TLP TL-FULL VIEW



Documentazione tecnica

Sezioni	3
Disposizione di finestre	4-6
Porta pedonale	7
Sezione invetriate	8
Tipi di sollevamento	9-14





R-500 & R-610 SEZIONI PER PORTONI SOLEVATI

R-500

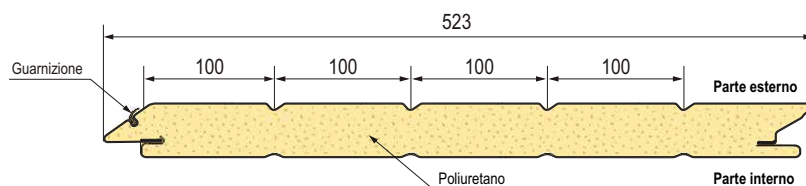
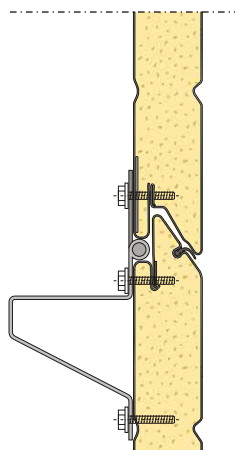

R-610

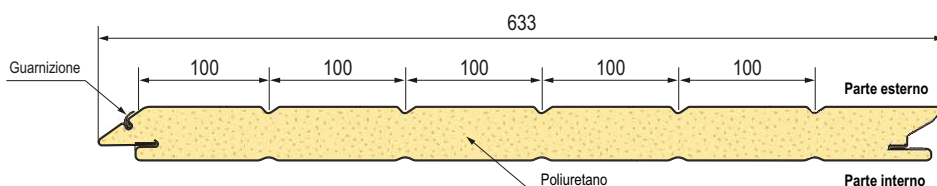

DATI:

Tipo di sezione	Spessore (mm)	K		Λ	Peso		Le dimensioni		
		Kcal/m ² hK	Watt/m ² K	Kcal/mK	Kg/m	Kg/m ²	Spessore	Altezza	Lunghezza
R-500	40	0,43	0,50	0,017	5,6	11,2	+/- 2	+/- 1	+/- 5
R-610					6,8	11,2			

Fattura standard d'esterno e d'interno - „stucco“

COLORI STANDARD:

Tipo di sezione	Parte interno		Parte esterno	
R-500		RAL 9002		RAL 9016
R-610		RAL 9002		RAL 9016

ALTRI COLORI FABBRICATI D'ESTERNO: RAL 9002, 9006, 8017, 7024, 6009, 6005, 5010



DISPOSIZIONE DI FINESTRE OVALI NEI PORTONI TLP

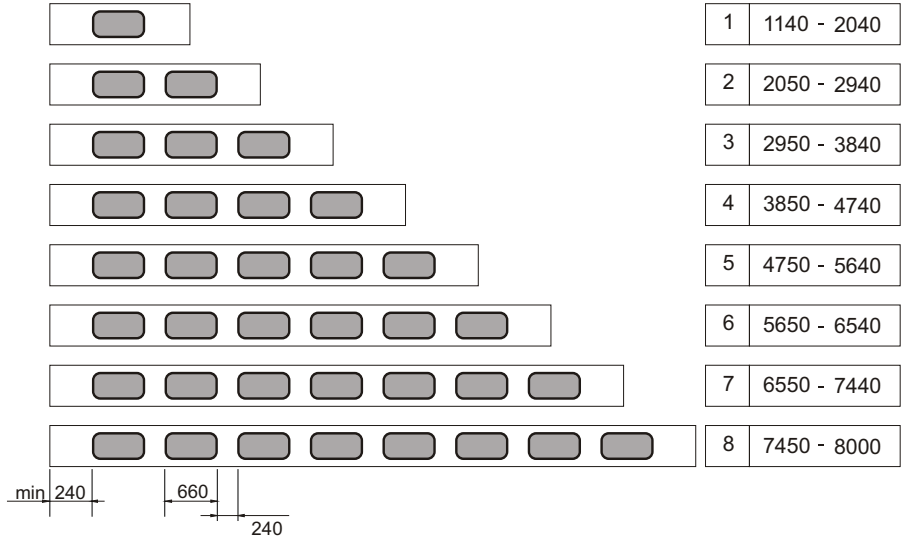
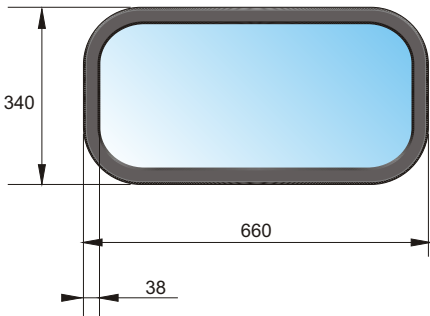

Sono possibili diverse varianti di disposizione delle finestre

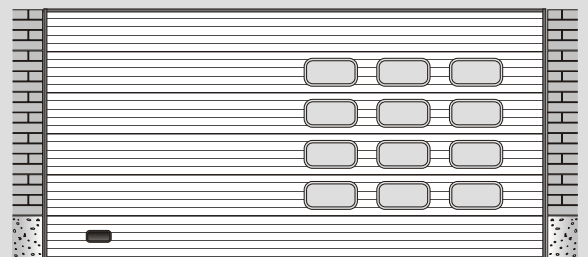
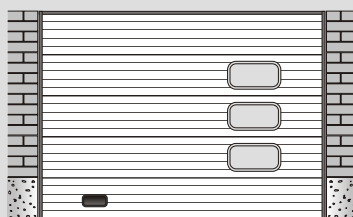
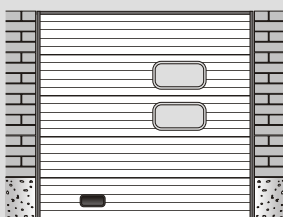
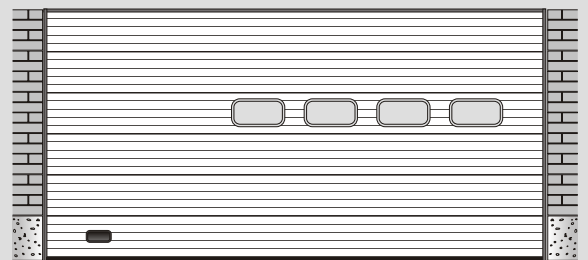
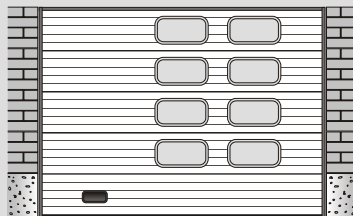
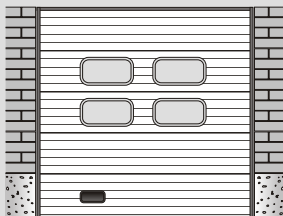
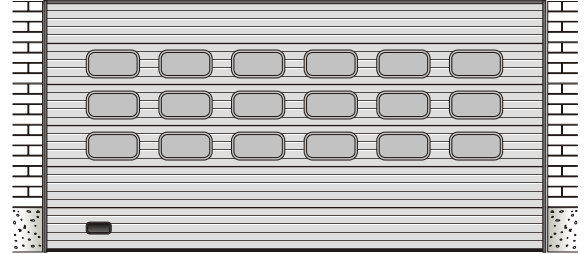
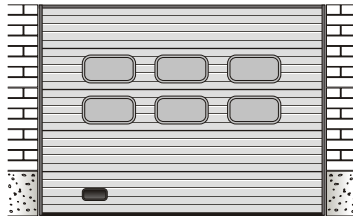
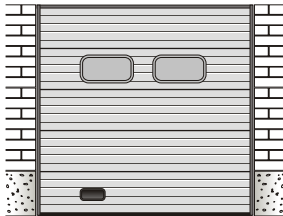



DISPOSIZIONE DI FINESTRE RETTANGOLARI NEI PORTONI TLP

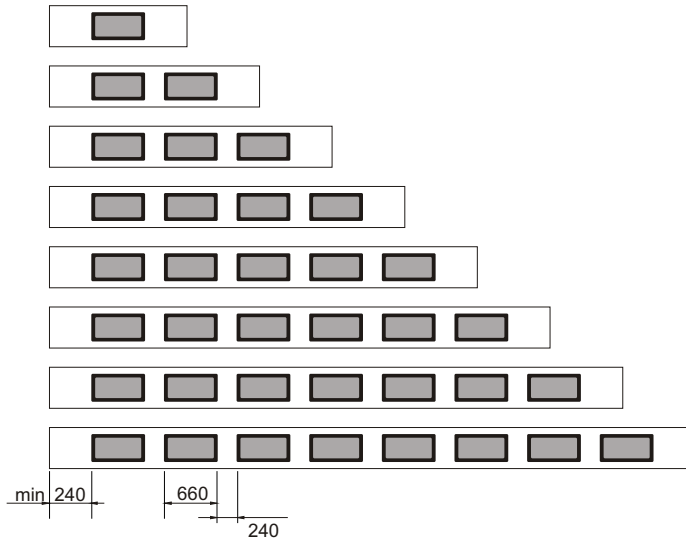
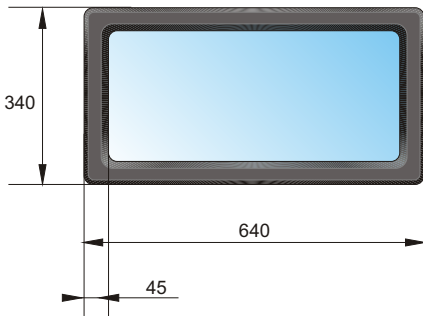

Quantità possibile di finestre nella sezione	larghezza della nicchia (B)
1	1140 - 2040
2	2050 - 2940
3	2950 - 3840
4	3850 - 4740
5	4750 - 5640
6	5650 - 6540
7	6550 - 7440
8	7450 - 8000

Sono possibili diverse varianti di disposizione delle finestre

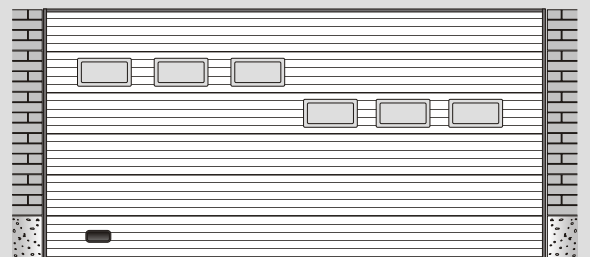
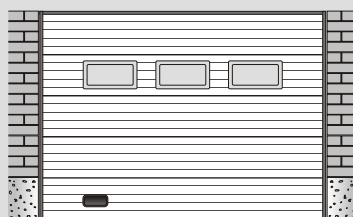
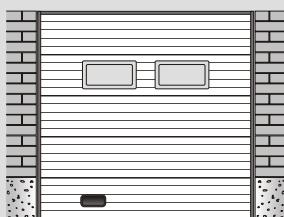
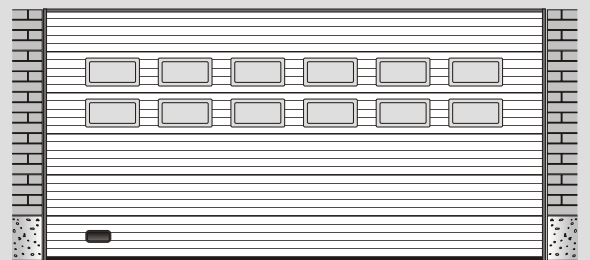
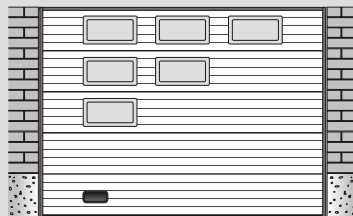
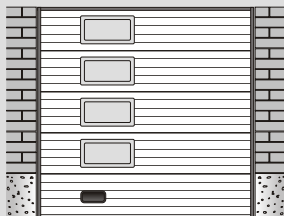
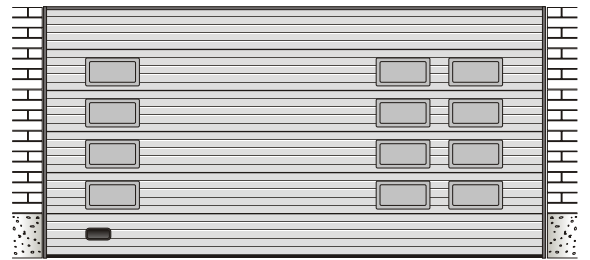
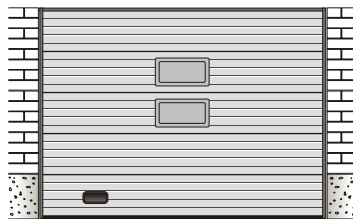
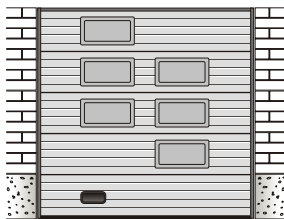



DISPOSIZIONE DI FINESTRE ROTONDE NEI PORTONI TLP

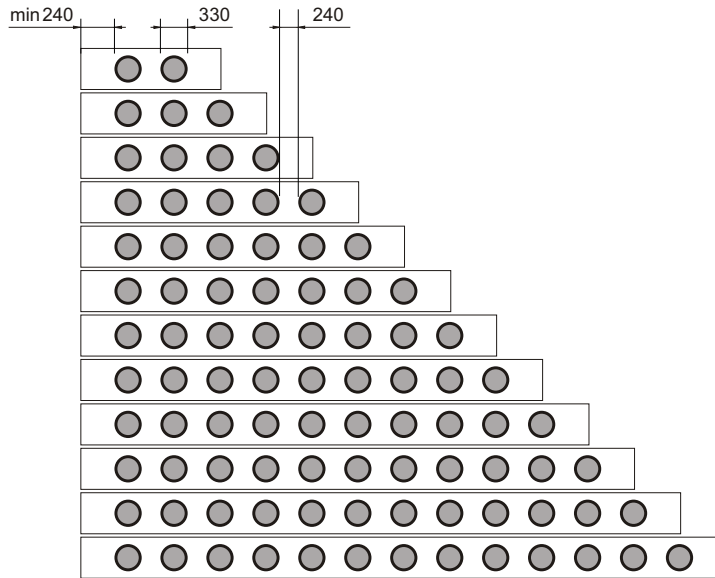
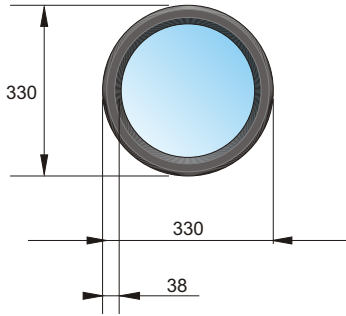

Quantità possibile di finestre nella sezione	larghezza della nicchia (B)
2	1380 - 1940
3	1950 - 2510
4	2520 - 3080
5	3090 - 3650
6	3660 - 4220
7	4230 - 4790
8	4800 - 5360
9	5370 - 5930
10	5940 - 6500
11	6510 - 7070
12	7080 - 7640
13	7650 - 8000

Sono possibili diverse varianti di disposizione delle finestre

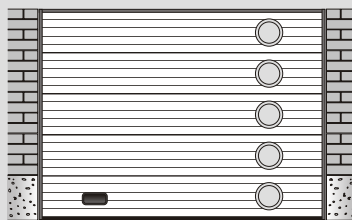
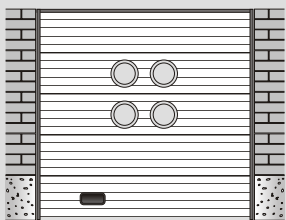
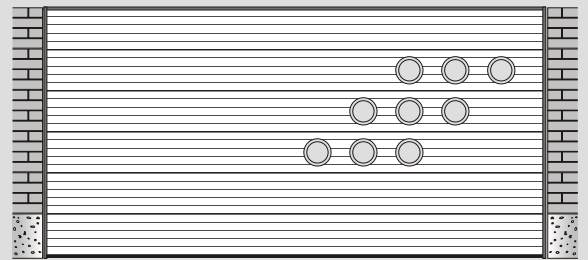
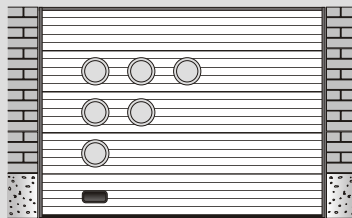
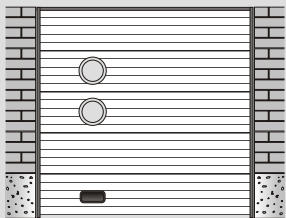
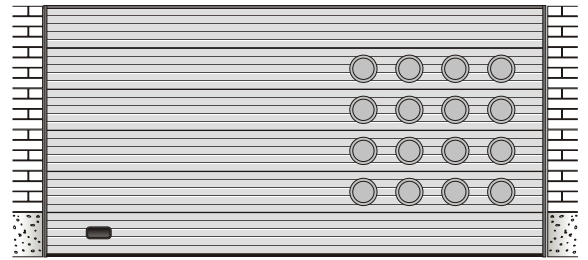
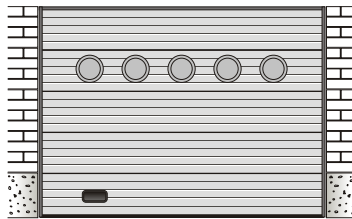
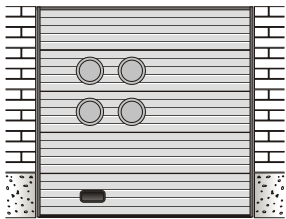



DISPOSIZIONE DELLE PORTE PEDONALI NEI PORTONI TLP

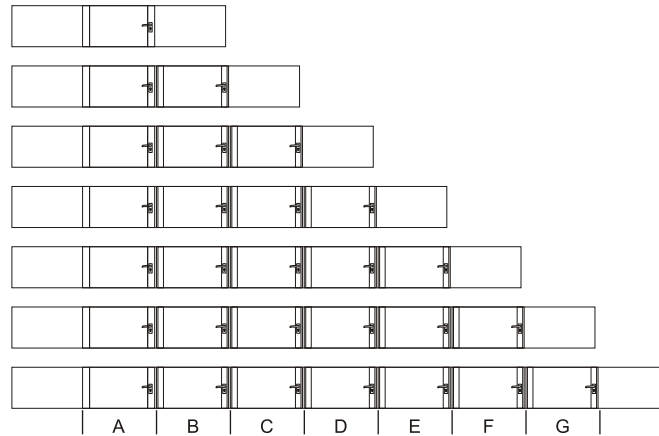
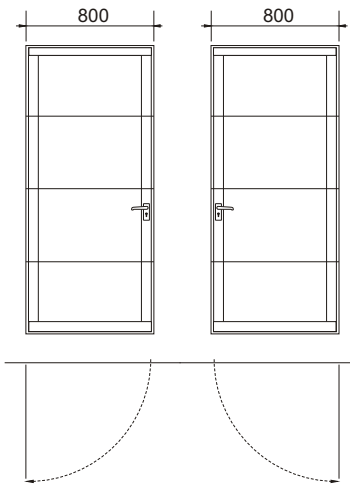

larghezza della nicchia (B)

1800 - 2690
2700 - 3590
3600 - 4490
4500 - 5390
5400 - 6290
6300 - 7190
7200 - 8000

La possibilità dei diversi posti delle porte pedonale dipende dalla superficie dei portoni (A-G)

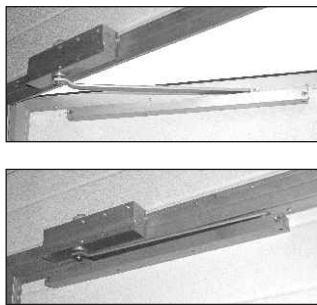

La molla chiudiporta assicura che la porta sia chiusa durante il processo di automazione del portone.

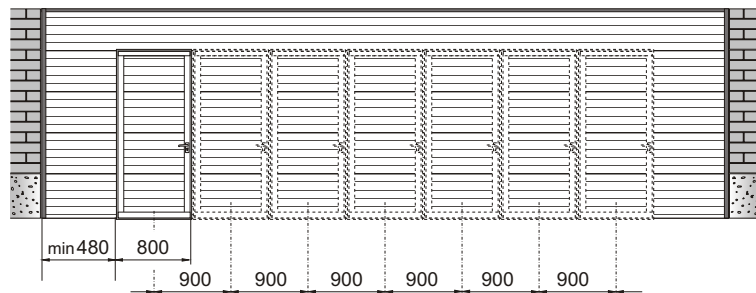

Sui portoni con porte le finestre possono essere montate in qualsiasi posto, lasciando una distanza di 900 mm dal centro della finestra.

*Su richiesta del cliente, le finestre e le porticine possono essere montate secondo progetti individuali.

Sono possibili più varianti della disposizione delle porte pedonale nei portoni con finestre.

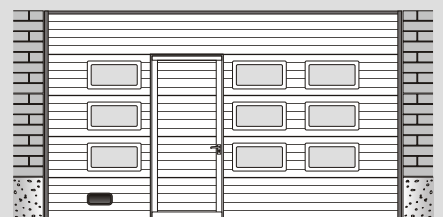
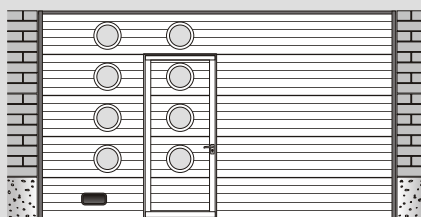
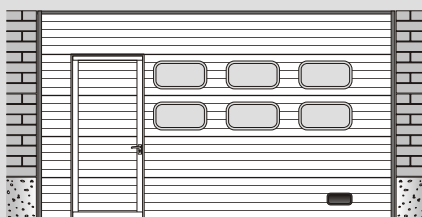
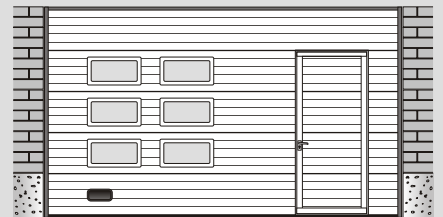
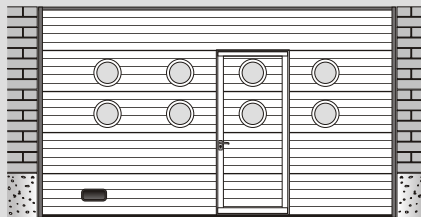

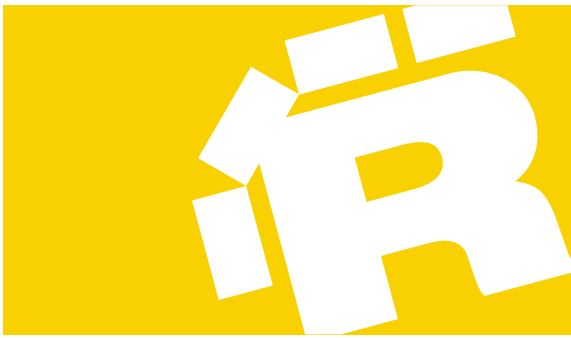

Disposizione di sezioni di alluminio invetriato nei portoni **TL-FV e LP**

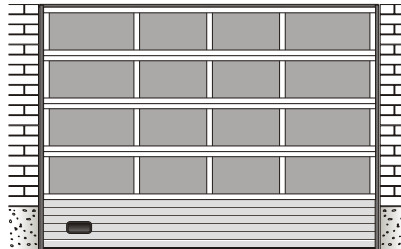
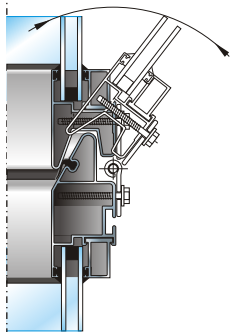
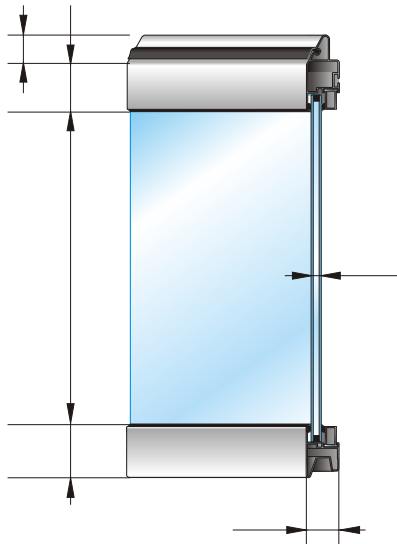

Portoni TL-FV standard; sezione sottostante tipo „Sandwich“

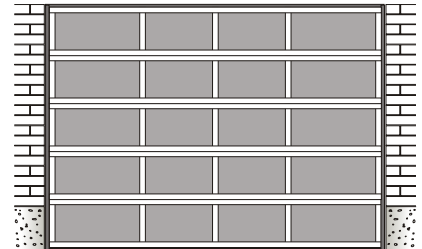

Portoni TL-FV con tutte le sezioni di alluminio invetriato

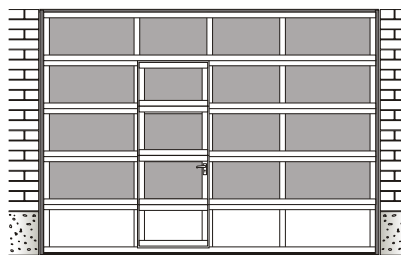

Sezione di alluminio sottostante le porte TL-FV con aggiunte isolanti

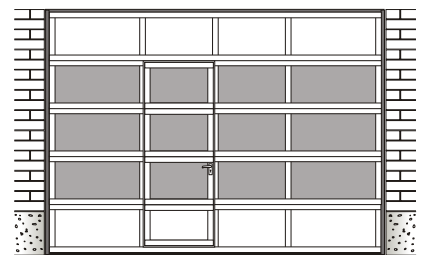

Alcune sezioni di alluminio con aggiunte isolanti nei portoni TL-FV

Su tutti i portoni TL-FV è possibile montare una porta pedonale. La porticina può situarsi in qualsiasi gruppo di finestre verticali tranne che alle estremità. La larghezza standard delle porticine è di 840 mm. Possono essere a destra o a sinistra, con apertura sull'esterno.

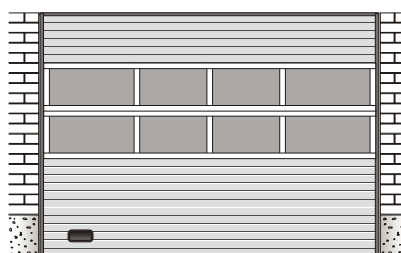
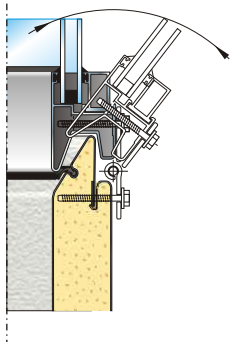

Portoni TLP con alcune sezioni in alluminio invetriato.



Portoni TLP con una sezione di alluminio invetriato.

Su tutti i portoni TLP con sezioni di alluminio invetriato è possibile montare porta pedonale.



MECCANICA STANDARD STD

TIPI DI SOLLEVAMENTO

- $h \geq 400$ mm (quando altezza della nicchia è 3250 mm)
- $h \geq 450$ mm (quando altezza della nicchia è 5200 mm)
- $h \geq 480$ mm (quando altezza della nicchia è più di 50 mm)

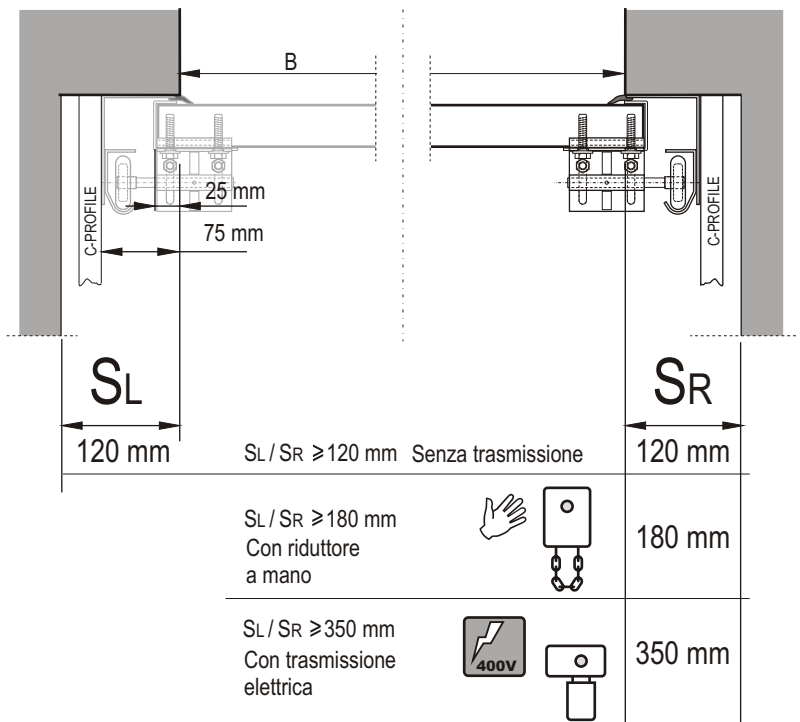
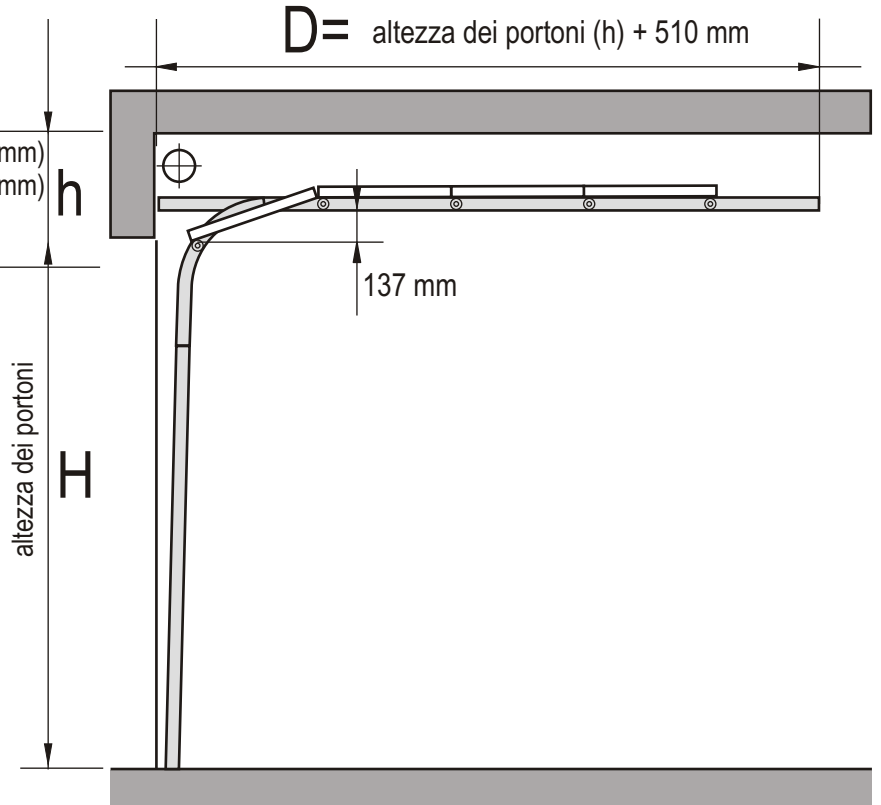
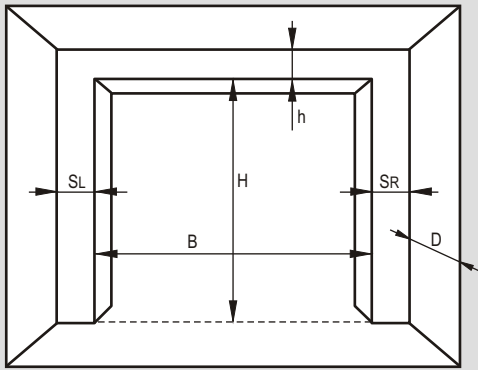

La trasmissione può essere montata anche sul lato sinistro. (SL)



LHR FM

meccanica ribassata, doppia guida, molla frontale

TIPI DI SOLLEVAMENTO

- $h \geq 250$ mm (quando altezza della nicchia è 3250 mm)
- $h \geq 320$ mm (quando altezza della nicchia è 5200 mm)
- $h \geq 360$ mm (quando altezza della nicchia è più di 5200 mm)

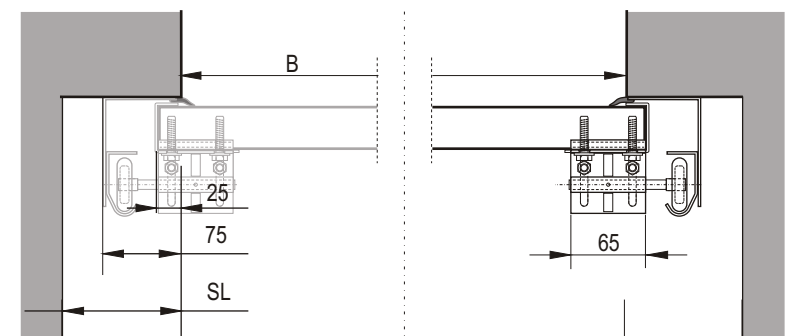
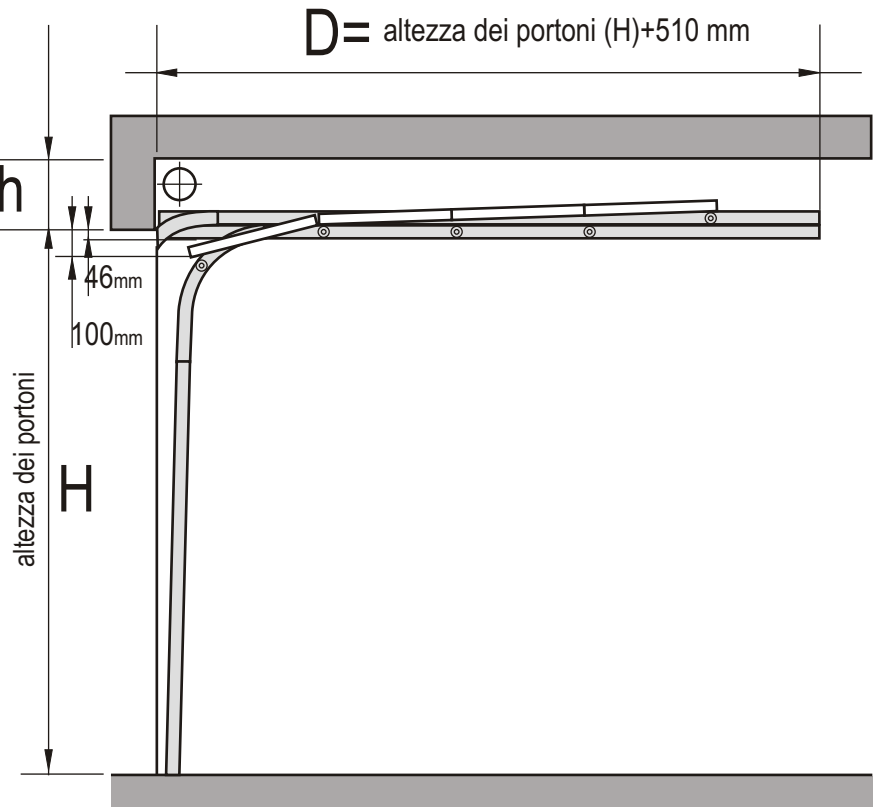
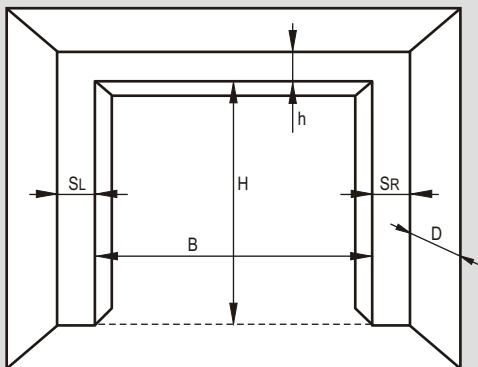

SL		SR
100 mm	SL / SR \geq 100 mm Senza trasmissione	100 mm
	SL / SR \geq 170 mm Con riduttore a mano	170 mm
	SL / SR \geq 350 mm Con trasmissione elettrica	350 mm

La trasmissione può essere montata anche sul lato sinistro. (SL)



LHR RM

meccanica ribassata, doppia guida, molla posteriore

TIPI DI SOLLEVAMENTO

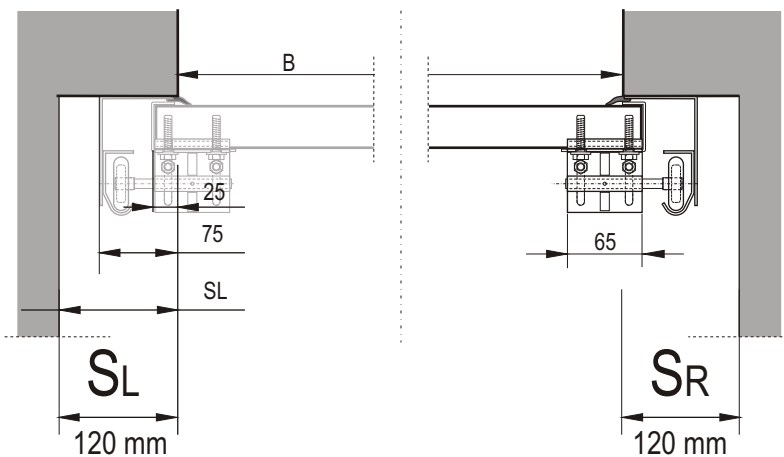
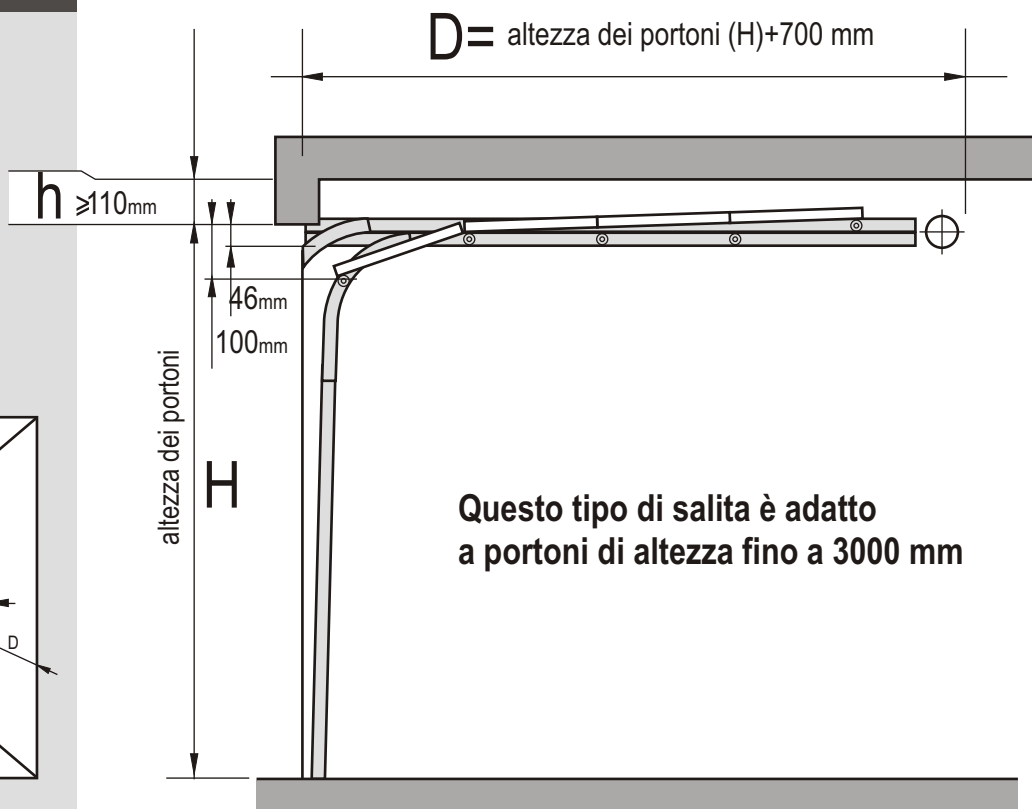
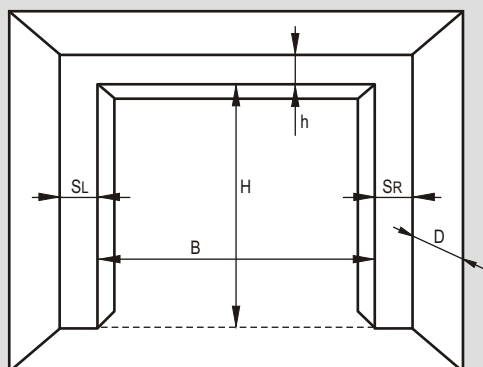



MECCANICA RIALZATA HL

TIPI DI SOLLEVAMENTO

$h \geq 1600$ mm
 $h \geq 1610 - 3350$ mm
 $h \geq 3360 - 4450$ mm

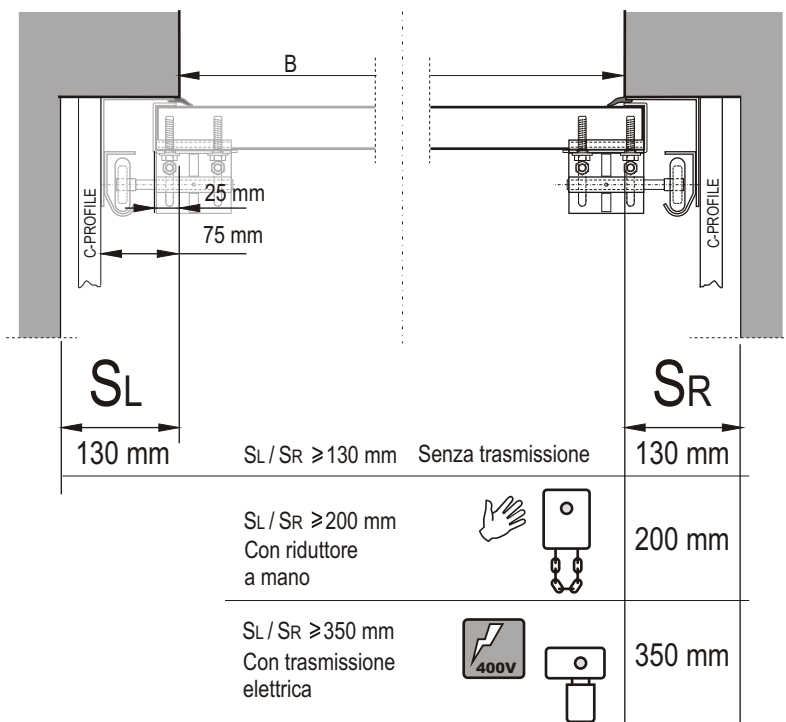
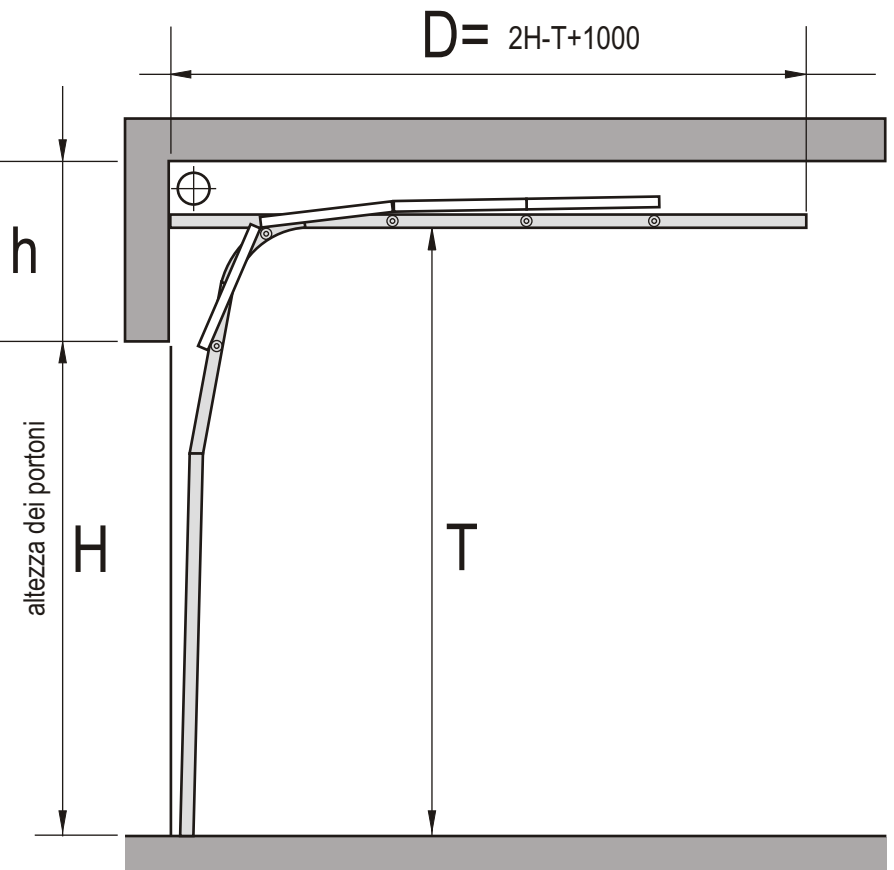
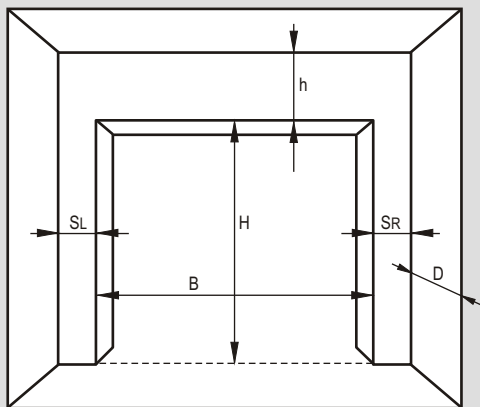

La trasmissione può essere montata anche sul lato sinistro. (SL)



MECCANICA VERTICALE, Molla in alto VL-TM

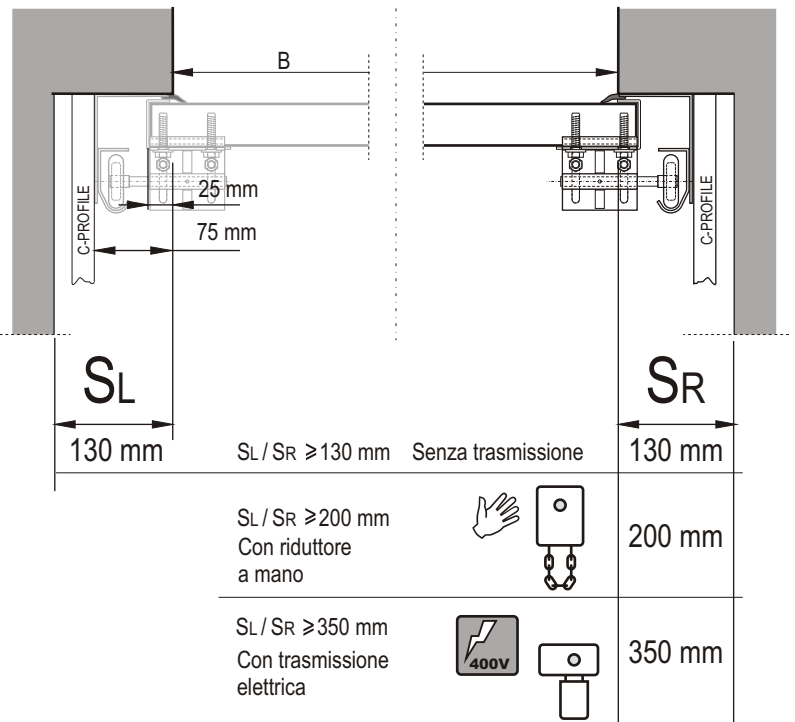
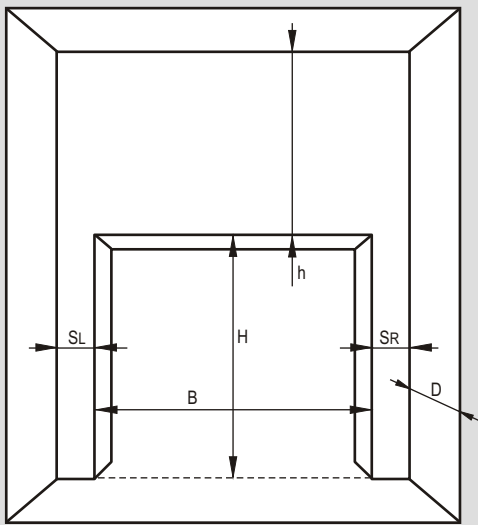
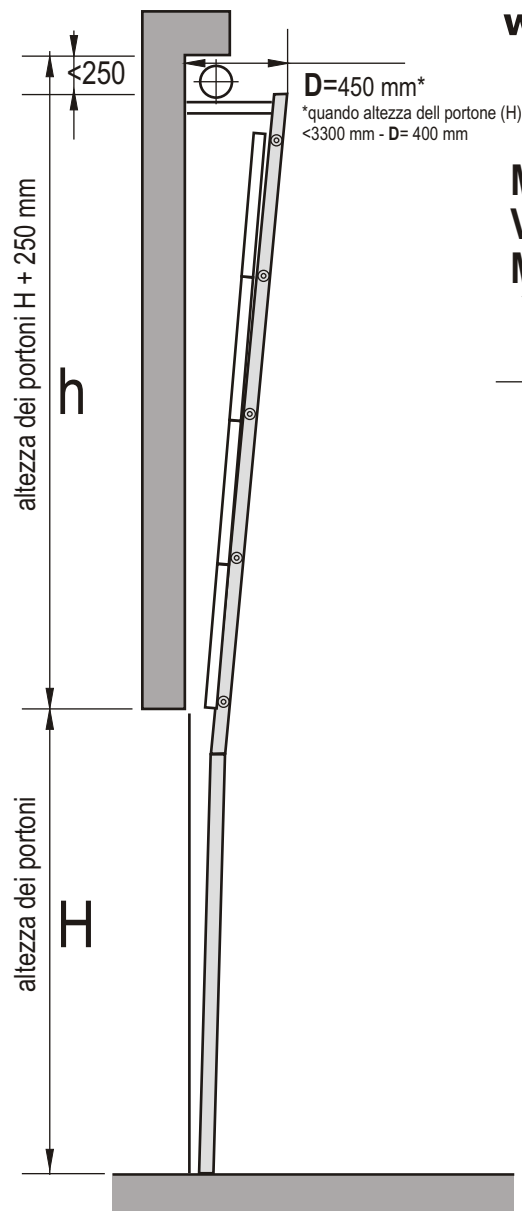

La trasmissione può essere montata anche sul lato sinistro. (SL)

TIPI DI SOLLEVAMENTO

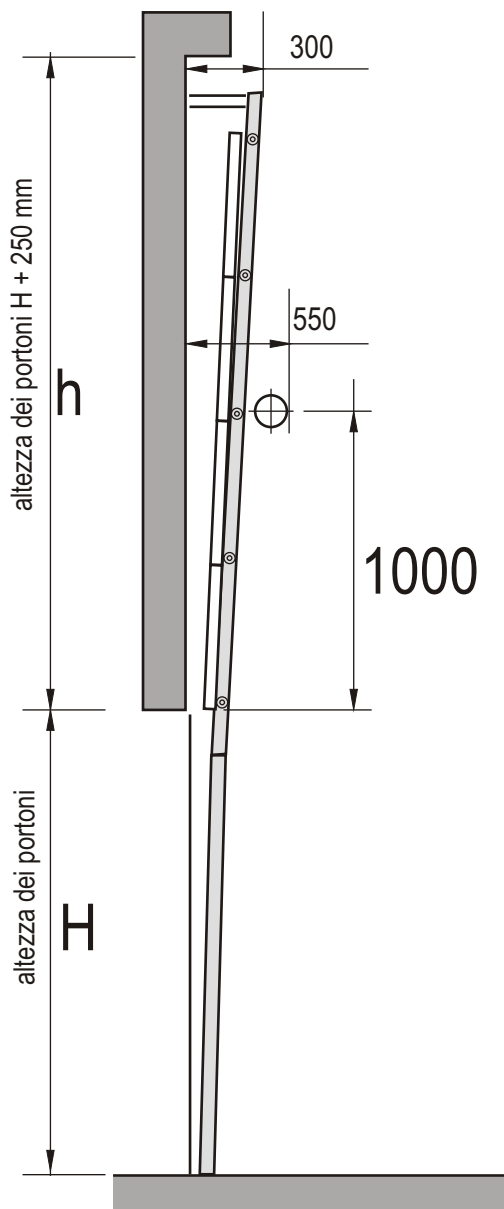
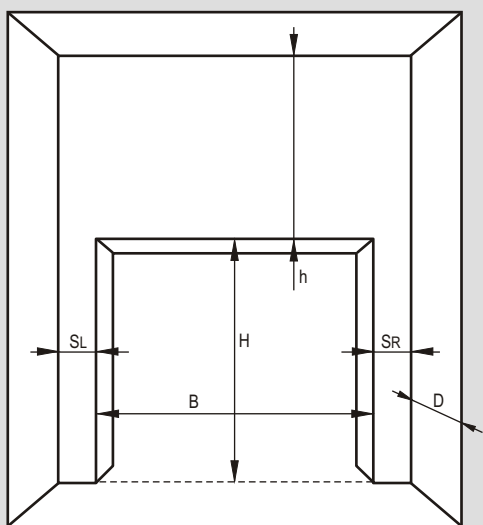

MECCANICA VERTICALE, molla ribasata VL-MM

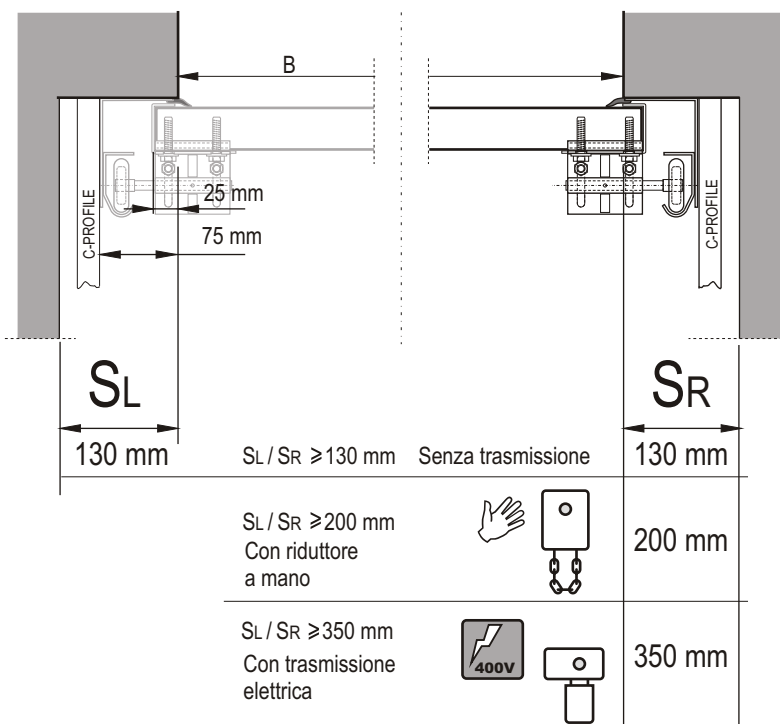

La trasmissione può essere montata anche sul lato sinistro. (SL)



RYTERNA

Ryterna UAB, Vandžiogalos Str. 84, LT - 47480 KAUNAS, Lithuania

Phone: +370 37 490997, Fax: +370 37 490991

e-mail: export@ryterna.lt

www.ryterna.it